

» VENTILADOR DE ANDEN 115V 1725RPM MARCA ROMLAIR MOD.R-DF-18, MOD.R-DF-14.

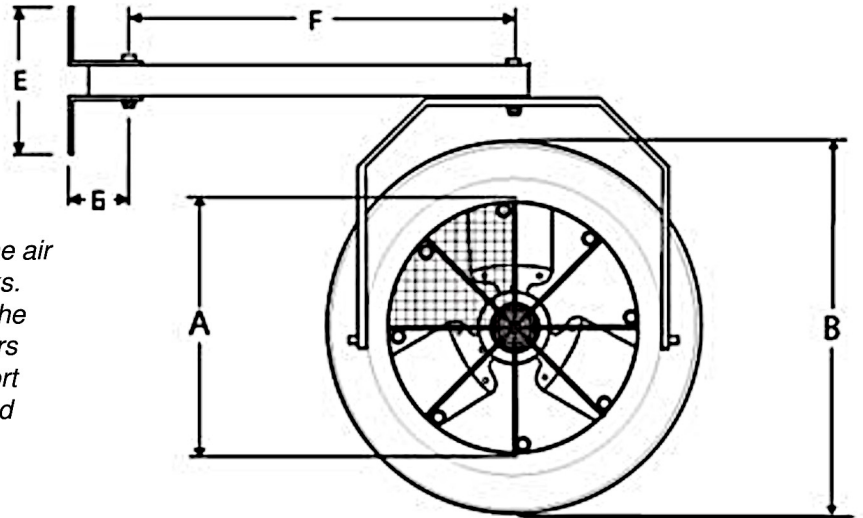

*Model R-DF Romulator  
Ultra-High Performance -  
Energy Saving Dock Door Fan*

The Romulator is designed for recirculating the air in semi-truck trailers and around loading docks. The new advanced design greatly increases the air velocity performance deep inside 53' trailers over other designs. This provides more comfort and higher productivity for workers loading and unloading inside the trailer.



**Features**

- Low amp applications
- Direct driven
- Attractive nozzle design with spun inlet bell
- Integral air straightener to reduce air swirl
- High performance zinc-alum propeller
- Heavy duty safety guards on both the inlet and outlet.
- Power cord furnished on 115v units only
- Fan housing coated with polyurethane yellow finish

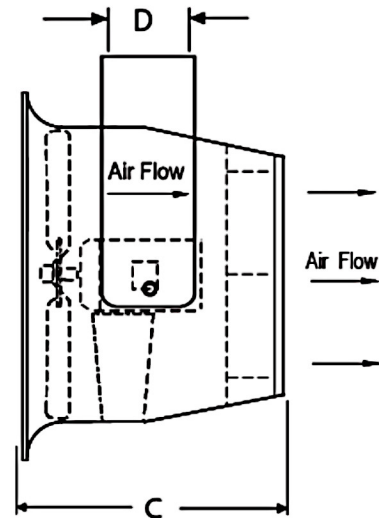

DIMENSIONS AND WEIGHTS											
SIZE MODEL	CFM	RPM	HP	A	B	C	D	E	F	G	SHIP WT
R-DF-18	3700	1725	1/2	16	24	17.5	4	10	22	7	86
R-DF-14	2500	1725	1/4	12.5	20	18	4	10	22	7	71



V03.23